

J. W. SEE.
Lathe-Carriage.

No. 208,496.

Patented Oct. 1, 1878

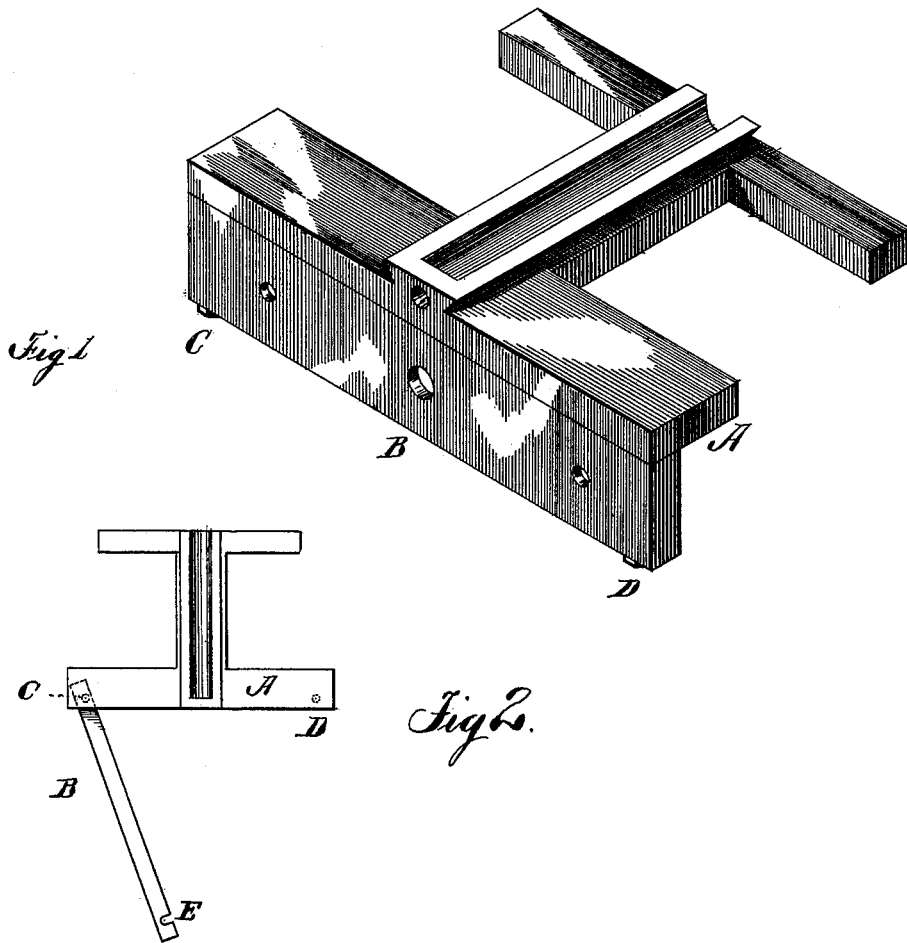

Witnesses
John R. Woods
H. H. Gray.

James W. See. Inventor

UNITED STATES PATENT OFFICE.

JAMES W. SEE, OF HAMILTON, OHIO.

IMPROVEMENT IN LATHE-CARRIAGES.

Specification forming part of Letters Patent No. **208,496**, dated October 1, 1878; application filed April 25, 1878.

To all whom it may concern:

Be it known that I, JAMES W. SEE, of Hamilton, Butler county, Ohio, have invented a new and useful Improvement in Lathe-Carriages, of which the following is a specification:

This invention relates to such lathe-carriages as are provided with a front apron, covering and protecting the mechanism within and behind the apron.

Such covered mechanism generally consists of more or less complex gearing, worms, worm-wheels, &c. In many cases there are revolving parts revolving upon revolving parts, and sliding parts sliding within sliding parts.

The mechanism is most always of an intricate character, and requires attention as regards cleanliness and lubrication. Heretofore the apron has been bolted rigidly to the saddle, and the designer has frequently caused the apron to not only contain its own distinctive mechanism, but also to furnish bearings and supports for sundry lead-screws, feed-rods, and reversing-rods. In such cases it often happens that, to obtain even a general view of the apron machinery, it will be necessary to remove all of the aforesaid lead-screws, feed-rods, reversing-rods, &c., together with their end appurtenances and fixtures, so that the apron may be removed entirely and blocked up in some position where its interior may be understandingly inspected and conveniently handled. This operation is always considered a nasty job, and it always requires two men to do it. In view of the magnitude and dirtiness of the undertaking, the process of overhauling, cleaning, and even oiling is generally postponed and delayed till actual necessity makes the matter imperative; for, be it known that behind the handsome apron of many lathes lie hidden mechanical contrivances which it is beyond the power of mortal man to lubricate while the apron is in position.

The object of my invention is to simplify the process of taking the lathe to pieces, in order to get at a wheel behind the apron.

The invention consists of a saddle with an apron hinged to it in such a manner that the

apron may be swung open, allowing its interior to be inspected and manipulated.

In the accompanying drawing, Figure 1 is a perspective view of my improved lathe-carriage, showing the apron as occupying its normal position; and Fig. 2 is a plan of the same, showing the apron as being swung out or open.

A is the saddle, and B is the apron, attached to the saddle by two vertical bolts or studs, C and D. These bolts are, respectively, pivot and latch bolts. The bolt C is the pivot-bolt, and its office is to furnish a bearing of rotation for the apron while swinging, a rigid support for the apron while swinging, a lowering-screw, by means of which the apron may be lowered before being swung open, and a means by which the apron may be firmly clamped to the saddle.

The office of the bolt D is to clamp the apron, as usual, to the saddle, and as this, its main office, would interfere with the swinging movement of the apron, it would be necessary to remove it entirely when the apron is to be swung open. To avoid the necessity of removing this bolt, I make use of a self-relieving feature, not at all novel, by the way, which will be described farther on, which allows this bolt to remain and perform the simple duties of a latching-bolt.

The bolt-hole E, at one end of the apron, is slotted out, leaving the back of the hole open, as shown in Fig. 2, so that, the two bolts being loosened, the apron may be swung open, hinging upon the pivot-bolt C. In this position the apron will be sustained, and may be cleaned, oiled, &c., with convenience. When closed and both bolts tightened all is solid again.

It should be mentioned aprons usually contain certain gears engaging with fixed racks, which would interfere with the movement of the apron.

In practice I obviate this simple difficulty by making the bolts C and D long enough to allow the apron to be dropped somewhat before it is swung open. This dropping of the apron clears all gears.

When the apron is closed the bolts are made to draw the gearing into position, and then to firmly fasten the apron to the saddle.

In designing a carriage of this character it will, of course, be desirable to attach all apron parts inseparable from the lead-screw and feed-rod to the saddle instead of to the apron, as heretofore.

I claim as my invention—
The saddle A, apron B, extensible pivot C, and latch-bolt D, all combined, substantially as and for the purpose specified.

JAMES W. SEE.

Witnesses:

CHAS. STENGEL,
D. M. STEVENSON.